

The logo for goodram, featuring the word "goodram" in a white, lowercase, sans-serif font on a dark blue rectangular background.

**industrial**

GOODRAM Industrial  
SD Memory Card MLC  
Silver-Gold-Diamond  
DATASHEET

Version: 1.2

Date: August 2020

SD Card for Industrial Applications

Wilk Elektronik S.A.

Mikołowska 42

43-173 Łaziska Górne, Poland

Tel.: +48 32 736 90 00, Fax.: +48 32 736 90 01

E-mail: [sales@goodram.com](mailto:sales@goodram.com)

All rights are strictly reserved. Any portion of this paper shall not be reproduced, copied or translated to any other forms without permission from Wilk Elektronik S.A.

This document is subject to change without any notice.

Please contact your Wilk Elektronik S.A. sales representative for details as to environmental matters such as the RoHS compatibility of Product. Please use Product in compliance with all applicable laws and regulations that regulate the inclusion or use of controlled substances, including without limitation, the EU RoHS Directive. Wilk Elektronik S.A. assumes no liability for damages or losses occurring as a result of noncompliance with applicable laws and regulations.

## REVISION HISTORY

VERSION	CHANGES	DATE
1.0	Initial release	08.10.2019
1.1	Logo amendment	18.06.2020
1.2	P/N Toshiba/Kioxia amendment	14.08.2020

## TABLE OF CONTENTS

REVISION HISTORY .....	3
PRODUCT OVERVIEW .....	5
PRODUCT DETAILS .....	6
GENERAL DESCRIPTION .....	6
PIN ASSIGNMENT .....	6
FLASH MANAGEMENT .....	7
STANDARDS & REFERENCES .....	11
SAFETY PRECAUTIONS.....	11
NOTES ON USAGE .....	12

## PRODUCT OVERVIEW

<ul style="list-style-type: none"> <li>• Capacity:           <ul style="list-style-type: none"> <li>○ 4GB – 128GB</li> </ul> </li> <li>• Flash Type           <ul style="list-style-type: none"> <li>○ Kioxia 15nm MLC</li> </ul> </li> <li>• Power Consumption <sup>Note1</sup> <ul style="list-style-type: none"> <li>○ Power Up Current &lt; 250uA</li> <li>○ Standby Current &lt; 1000uA</li> <li>○ Read Current &lt; 400mA</li> <li>○ Write Current &lt; 400mA</li> </ul> </li> <li>• Performance           <ul style="list-style-type: none"> <li>○ Read: Up to 95MB/s</li> <li>○ Write: Up to 90MB/s</li> </ul> </li> <li>• Endurance           <ul style="list-style-type: none"> <li>○ 3000 erase/program cycles in whole capacity</li> <li>○ Data retention over 10 years in room temperature (25°C) <sup>Note2</sup></li> </ul> </li> </ul>	<ul style="list-style-type: none"> <li>• Controller           <ul style="list-style-type: none"> <li>○ PS8210</li> </ul> </li> <li>• Advanced Flash Management           <ul style="list-style-type: none"> <li>○ Static and Dynamic Wear Leveling</li> <li>○ Bad Block Management</li> <li>○ SMART Function <sup>Note3</sup></li> <li>○ Auto-Read Refresh</li> <li>○ Embedded Mode <sup>Note3</sup></li> </ul> </li> <li>• Operating Voltage range           <ul style="list-style-type: none"> <li>○ 2.7 – 3.6 V</li> </ul> </li> <li>• Temperature Range <sup>Note4</sup> <ul style="list-style-type: none"> <li>○ Operation: Silver: 0 ~ +70°C</li> <li>○ Operation: Gold: -25°C ~ +85°C</li> <li>○ Operation: Diamond: -40°C ~ +85°C</li> <li>○ Storage: -40°C ~ +85°C</li> </ul> </li> <li>• MTBF           <ul style="list-style-type: none"> <li>○ More than 3 000 000 hours</li> </ul> </li> </ul>
--	---

## Notes:

1. Please see “Power Consumption” for details.
2. In new product
3. This function is enabled by customer requirement.
4. According to IEC-60068-2-1/2/14/38 standard.

## PRODUCT DETAILS

### GENERAL DESCRIPTION

The Secure Digital (SD) card version 6.x is fully compliant to the specification released by SD Card Association. The Command List supports [Part 1 Physical Layer Specification Ver3.01 Final] definitions. Card Capacity of Non-secure Area, Secure Area Supports [Part 3 Security Specification Ver3.00 Final] Specifications.

The SD 6.x card is based on 9-pin interface, designed to operate at a maximum operating frequency of 100MHz. It can alternate communication protocol between the SD mode and SPI mode. It performs data error detection and correction with very low power consumption.

### PIN ASSIGNMENT

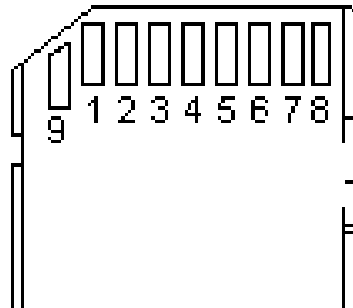

PIN	SD MODE			SPI MODE		
	NAME	TYPE	DESCRIPTION	NAME	TYPE	DESCRIPTION
1	CD/DAT3	I/O/PP	Card Detect/ Data Line [bit3]	CS	I	Chip Select (net true)
2	CMD	PP	Command/Response	DI	I	Data In
3	VSS	S	Supply voltage ground	VSS	S	Supply voltage ground
4	VDD	S	Supply Voltage	VDD	S	Supply Voltage
5	CLK	I	Clock	SCLK	I	Clock
6	VSS	S	Supply voltage ground	VSS	S	Supply voltage ground
7	DAT0	I/O/PP	Data Line [bit0]	DO	O/PP	Data Out
8	DAT1	I/O/PP	Data Line [bit1]	RSV		
9	DAT2	I/O/PP	Data Line [bit2]	RSV		

## FLASH MANAGEMENT

GOODRAM SD card utilizes all the state of art technologies to ensure full reliability until the specified NAND Flash program/erase cycles parameter is reached. These technologies include but are not limited to:

### Error Correction Code (ECC)

Flash memory cells will deteriorate with use, which may generate random bit errors in the stored data. To ensure the highest reliability, GOODRAM SD card applies the BCH ECC Algorithm, which can detect and correct errors that occur during read process, to ensure data is read correctly, as well as protected from corruption.

### Wear Levelling

Storage devices based on NAND flash memory, can only undergo a limited number of program/erase cycles, and due to various usage scenarios, data may not be distributed evenly between NAND flash chips. If a certain area gets updated more frequently than others, the lifetime of the device will be reduced significantly. Wear Leveling algorithm used in GOODRAM SD cards is used to extend the lifespan of NAND Flash by evenly distributing write and erase cycles across the whole storage area. Moreover, by utilizing both dynamic and static Wear Leveling algorithms, the life expectancy of GOODRAM SD cards can meet the listed specification.

### Bad Block Management

Bad blocks are blocks that include one or more invalid bits, and their reliability is not guaranteed. Blocks that are identified and marked as bad by the manufacturer are referred to as "Initial Bad Blocks". Bad blocks that are developed during the lifespan of the flash are named "Later Bad Blocks". GOODRAM SD card uses an efficient bad block management algorithm to detect all types of bad blocks, which further prevents data being stored into them and improves the data reliability.

### SMART Function

SMART, an acronym for Self-Monitoring, Analysis and Reporting Technology, is a special function that allows a memory device automatically monitor its health.

### Auto-Read Refresh

Auto-Read Refresh is especially applied on devices that read data mostly but rarely write data. When blocks are continuously read, then the device cannot activate wear leveling since it can only be applied while writing data. Thus, errors will accumulate and become uncorrectable. Accordingly, to avoid errors exceed the amount ECC can correct and blocks turn bad, firmware will automatically refresh the bit errors when the error number in one block approaches the threshold, ex. 24 bits.

**industrial**

## Embedded Mode

Embedded mode is a function specially designed for operating systems that not utilize FAT. Often under non Windows OS, for example Linux or customized host, wear leveling mechanism will be affected or even disabled in some cases. With embedded mode activated, wear leveling mechanism can operate normally to keep the usage of blocks even throughout the card's life cycle.

## COMPARING SD3.0, SDHC AND SDXC

	SD3.0 Standard (Backward compatible to 2.0 host)	SD3.0 SDHC/SDXC (Backward compatible to 2.0 host)
Addressing Mode	Byte (1 byte unit)	Block (512 byte unit)
HCS/CCS bits of ACMD41	Support	Support
CMD8 (SEND_IF_COND)	Support	Support
CMD16 (SET_BLOCKLEN)	Support	Support (Only CMD42)
Partial Read	Support	Not Support
Lock/Unlock Function	Mandatory	Mandatory
Write Protect Groups	Optional	Not Support
Supply Voltage 2.0v – 2.7v (for initialization)	Not Support	Not Support
Total Bus Capacitance for each signal line	40pF	40pF
CSD Version (CSD_STRUCTURE Value)	1.0 (0x0)	2.0 (0x1)
Speed Class	Optional	Mandatory (Class 2/4/6/10)

## PERFORMANCE AND POWER CONSUMPTION

Capacity	Flash Structure	Performance		Power Consumption (Maximum)		
		Read (MB/s)	Write (MB/s)	Read (mA)	Write (mA)	Standby (mA)
4GB	4GB x 1	90	10	400	400	1
8GB	8GB x 1	95	20	400	400	1
16GB	8GB x 2	95	50	400	400	1
	16GB x 1		20			
32GB	8GB x 4	95	90	400	400	1
	16GB x 2		45			
64GB	8GB x 8	95	90	400	400	1
	16GB x 4					
128GB	16GB x 8	95	90	400	400	1

## Notes:

1. Performance may vary from flash configuration and platform.
2. The table above is for your reference only. The criteria for mass production and for accepting goods shall be discussed based on different flash configuration.
3. Data transfer mode is single channel.
4. Power Consumption may differ according to flash configuration, SDR configuration, or platform.



**industrial**

PARAMETER	RATING
Operating voltage	2.7 – 3.6V +/- 5%

## Temperature specification

SYMBOL	PARAMETER	MIN.	MAX.	UNIT
T <sub>a</sub>	Operating Temperature Gold	-25	+85	°C
T <sub>a</sub>	Operating Temperature Diamond	-40	+85	°C
T <sub>st</sub>	Storage Temperature	-40	+85	°C

## PRODUCT ORDERING INFORMATION

PN	Type	Capacity	Technology	Temp range	Grade
RUSDCM004CXSB-P8EKI5	SD	4GB	MLC	0~70°C	silver
RUSDCM008CXSB-P8EKI5	SD	8GB	MLC	0~70°C	silver
RUSDCM016CXSB-P8EKI5	SD	16GB	MLC	0~70°C	silver
RUSDCM032CXSB-P8EKI5	SD	32GB	MLC	0~70°C	silver
RUSDCM064CXSB-P8EKI5	SD	64GB	MLC	0~70°C	silver
RUSDCM128CXSB-P8EKI5	SD	128GB	MLC	0~70°C	silver
RUSDCM004CXGB-P8EKI5	SD	4GB	MLC	-25~85°C	gold
RUSDCM008CXGB-P8EKI5	SD	8GB	MLC	-25~85°C	gold
RUSDCM016CXGB-P8EKI5	SD	16GB	MLC	-25~85°C	gold
RUSDCM032CXGB-P8EKI5	SD	32GB	MLC	-25~85°C	gold
RUSDCM064CXGB-P8EKI5	SD	64GB	MLC	-25~85°C	gold
RUSDCM128CXGB-P8EKI5	SD	128GB	MLC	-25~85°C	gold
RUSDCM004CXDB-P8EKI5	SD	4GB	MLC	-40~85°C	diamond
RUSDCM008CXDB-P8EKI5	SD	8GB	MLC	-40~85°C	diamond
RUSDCM016CXDB-P8EKI5	SD	16GB	MLC	-40~85°C	diamond
RUSDCM032CXDB-P8EKI5	SD	32GB	MLC	-40~85°C	diamond
RUSDCM064CXDB-P8EKI5	SD	64GB	MLC	-40~85°C	diamond
RUSDCM128CXDB-P8EKI5	SD	128GB	MLC	-40~85°C	diamond

PHYSICAL DIMENSION

Dimension: 32mm(L) x 24mm(W) x 2.1mm(H)

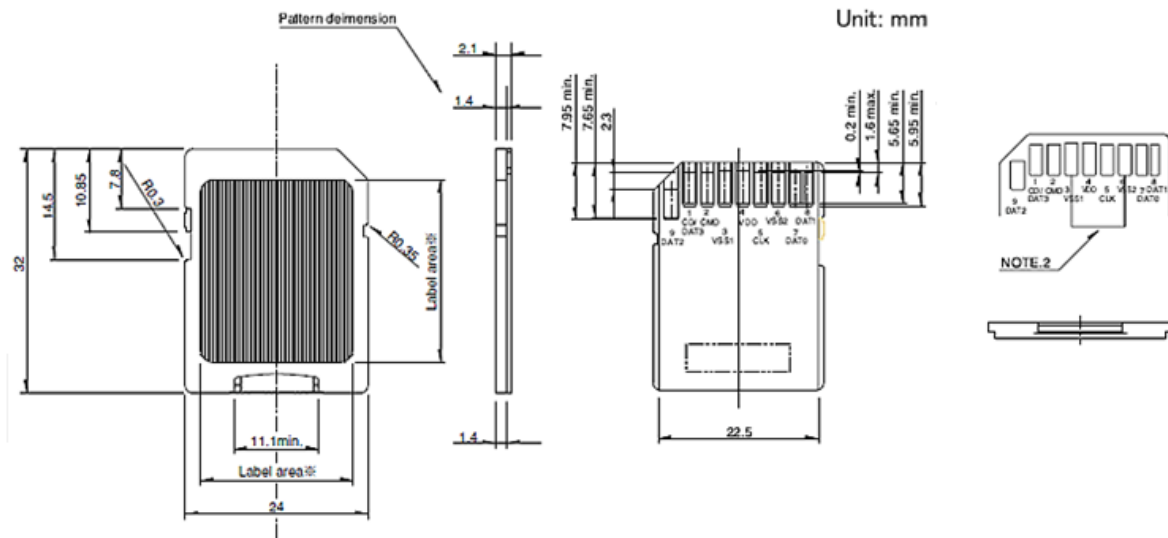

## STANDARDS & REFERENCES

The following table is to list out the standards that have been adopted for designing the product.

STANDARD USED	ACRONYM/SOURCE
RoHS	Restriction of Hazardous Substances Directive
SD specification	<a href="http://www.sdcard.org">http://www.sdcard.org</a>
CE	Consumer electronics certification; please contact us for further information.

## SAFETY PRECAUTIONS

Do not bend, crush, drop, or place heavy objects on top of the Product. Do not use tweezers, pliers or similar items that could damage the Product. Take particular care when inserting or removing the Product. Stop using the Product when the Product does not work properly. Failure to follow these instructions could result in fire, damage to the Product and/or other property, and/or personal injury including burns and electric shock.

Keep out of reach of small children. Accidental swallowing may cause suffocation or injury. Contact a doctor immediately if you suspect a child has swallowed the Product.

Do not directly touch the interface pins, put them in contact with metal, strike them with hard objects or cause them to short. Do not expose to static electricity.

Do not disassemble or modify the Product. This may cause electric shock, damage to the Product or fire.

## NOTES ON USAGE

The Product contains nonvolatile semiconductor memory. Do not use the Product in accordance with a method of usage other than that written in the manual. This may cause the destruction or loss of data.

To protect against accidental data loss, you should back up your data frequently on more than one type of storage media. Wilk Elektronik S.A. assumes no liability for destruction or loss of data recorded on the Card for any reason.

When used over a long period of time or repeatedly, the reading, writing and deleting capabilities of the Product will eventually fail, and the performance speed of the Product may decrease below the original speed specific to the Product's applicable class.

If the Product is to be transferred or destroyed, note that the data it contained may still be recoverable unless it is permanently deleted by third-party deletion software or similar means beforehand.

Product is intended for use in general electronics applications and selected industrial applications and any other specific applications as expressly stated in this document. Product is neither intended nor warranted for use in equipment or systems where failure may cause loss of human life, bodily injury, serious property damage or serious public impact ("Unintended Use"). Unintended Use includes, without limitation, equipment used in nuclear facilities, equipment used in the aerospace industry, medical equipment or equipment used to control combustions or explosions. Do not use Product for Unintended Use unless specifically permitted in this document.

No parts of this document may be reproduced, stored in a retrieval system, or transmitted, in any form or by any means, mechanical, electric, photocopying, recording or otherwise, without permission of Wilk Elektronik S.A.

Wilk Elektronik S.A does not make any warranty, express or implied, with respect to this document, including as to licensing, Non-infringement, merchantability or fitness for a particular purpose.